

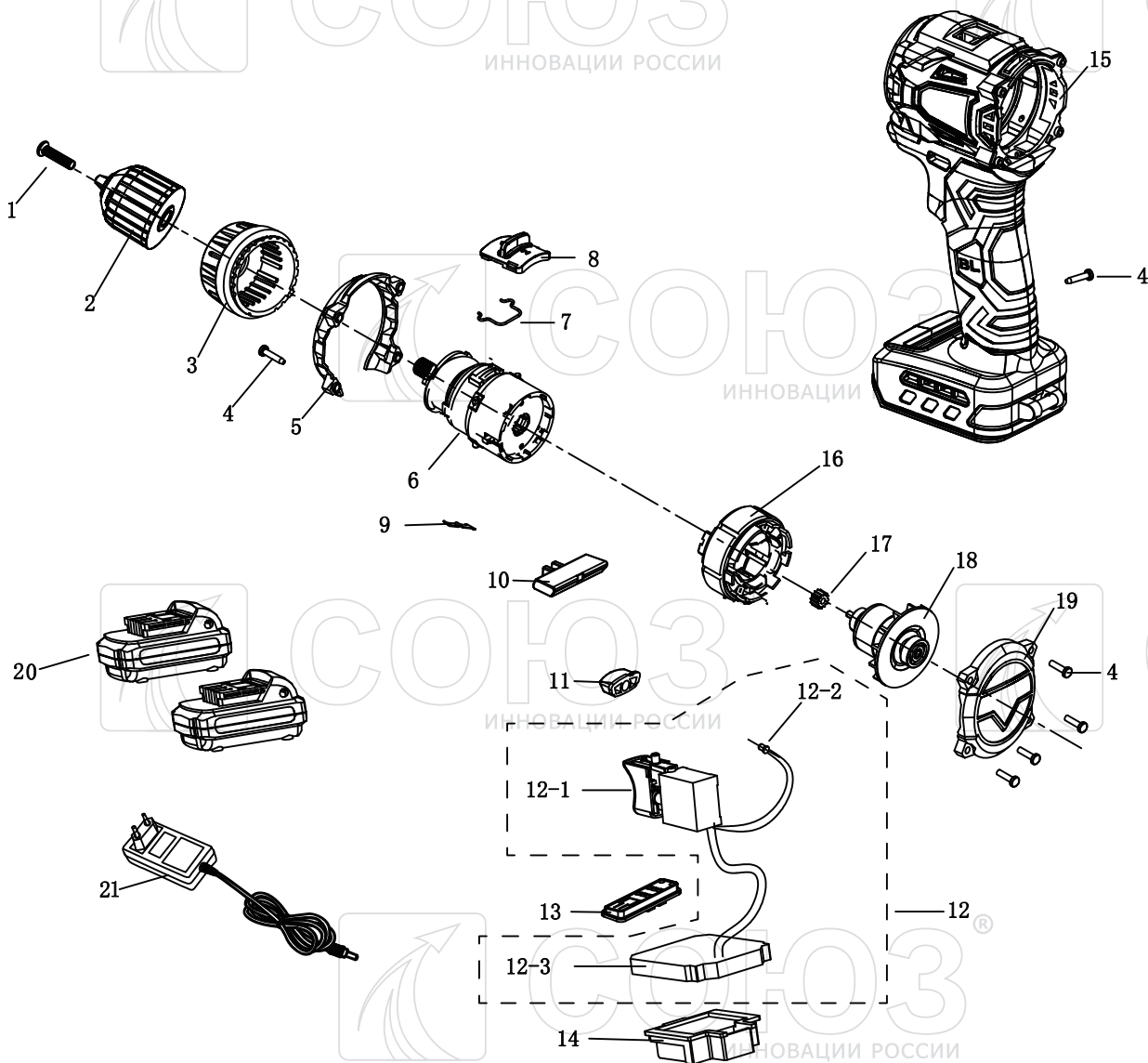

СОЮЗ[®]
ИННОВАЦИИ РОССИИ



ДШС-1845

NO.	DESCRIPTION
1	LEFT SCREW M5X20
2	KEYLESS CHUCK
3	TORQUE ADJUSTEMENT RING
4	SCREW ST3X14
5	FRONT COVER
6	GEAR BOX ASSEMBLY
7	STEEL WIRE
8	TWO SPEED PUSH BUTTON
9	METAL DOME
10	DIRECTION SWITCH
11	TRANSPARE COVER
12	PCB ASSMBLY
12-1	SWITCH
12-2	LED
12-3	PCB
13	BATTERY CAPACITY PCB
14	CONNECTOIN FOOT
15	HOUSING
16	STATOR
17	MOTOR GEAR
18	ROTOR
19	REAR COVER
20	BATTERY PACK
21	CHARGER

DSS-1845-EX-RU240912-1
ИННОВАЦИИ РОССИИ